

- NOTES:
- MATERIAL:
    - HOUSING: THERMOPLASTIC, HIGH TEMP., UL94V-0;
    - CONTACT: HIGH CONDUCTIVITY COPPER ALLOY
    - GROUND PLATE: STAINLESS STEEL
    - EMC PAD: STAINLESS STEEL
    - OUTER SHELL: STAINLESS STEEL
    - INNER SHELL: STAINLESS STEEL
  - FINISH:
    - CONTACT:
      - GOLD FLASH. ON CONTACT AREA.
      - 30u" Au MIN. ON CONTACT AREA.
      - 80u" MIN NICKEL UNDERPLATING OVERALL.
      - SOLDER TAILS: MATTE TIN 60u" MIN. OVER NICKEL.
    - GROUND PLATE & SHELL :
      - MATTE Sn 60u" MIN ON SOLDERING AREA
      - 50u" MIN NICKEL UNDERPLATING OVERALL.
  - SPEC. PLS. REFER TO PS-55907-xxxx-xxx
  - PACKAGE PLS REFER TO 55999-xxxx-xx-TRP
  - PART NUMBER

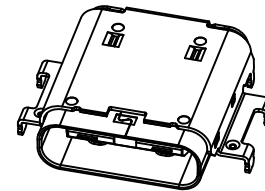
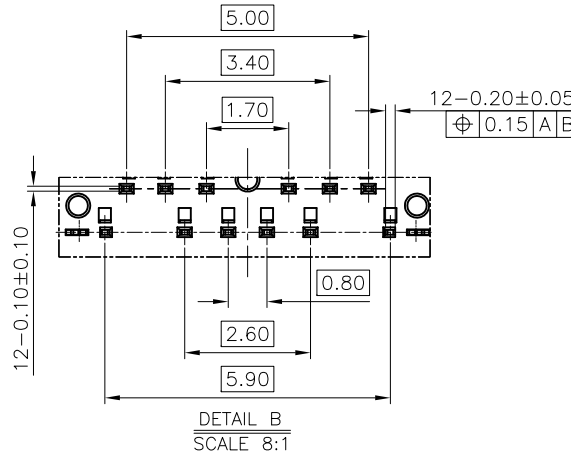
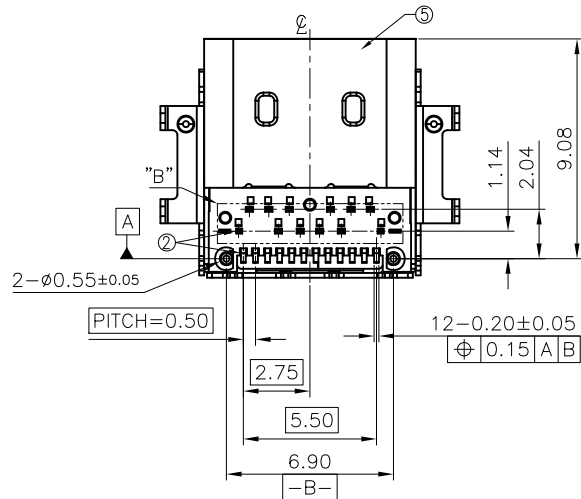
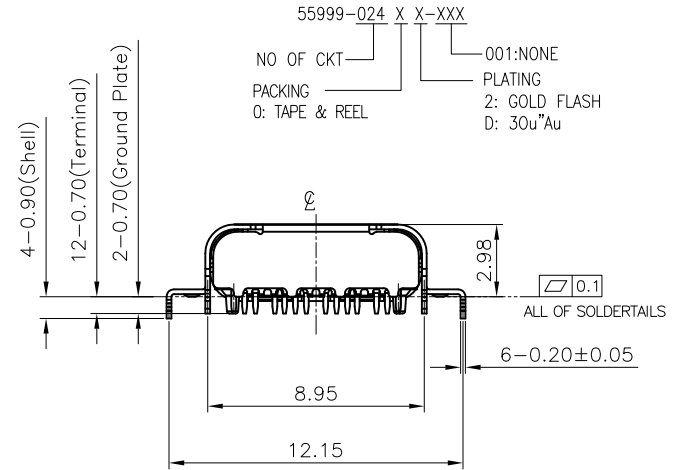
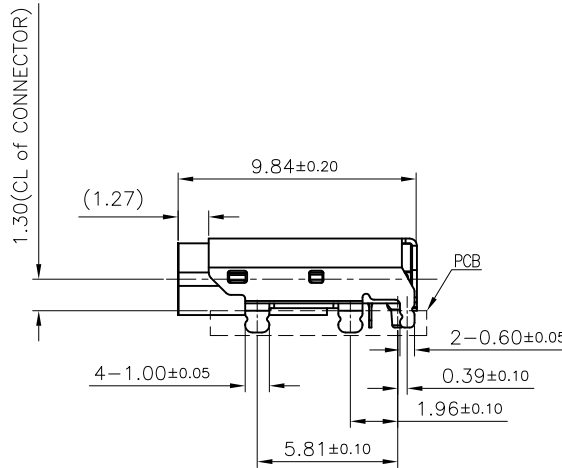
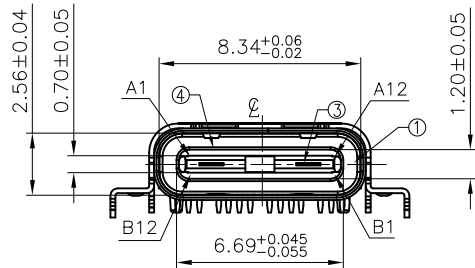

6	OUTER SHELL	1
5	INNER SHELL	1
4	EMC PAD	1
3	GROUND PLATED	1
2	CONTACT	24
1	HOUSING	1
ITEM	NAME	Q'TY

PIN NO.	A1	A2	A3	A4	A5	A6	A7	A8	A9	A10	A11	A12
SIGNAL NAME	GND	SSTxp1	SSTXn1	VBUS	CC1	Dp1	Dn1	SBU1	VBUS	SSRXn2	SSRXp2	GND
PIN NO.	B12	B11	B10	B9	B8	B7	B6	B5	B4	B3	B2	B1
SIGNAL NAME	GND	SSRXp1	SSRXn1	VBUS	SBU2	Dn2	Dp2	CC2	VBUS	SSTXn2	SSTXp2	GND

一般公差  
TOLERANCES

X ±0.50 .XX ±0.15  
X ±0.20 .XXX ±0.10

ANGLES X° ±3° .X° ±2° .XX° ±1°

檢驗尺寸標示  
SYMBOLS (M) (L) INDICATE CLASSIFICATION DIMENSION

(M) MARK IS CRITICAL DIM.  
(L) MARK IS MAJOR DIM.

表面處理 (FINISH)

宏致電子股份有限公司  
Aces Electronics Co., Ltd.

品名 (TITLE)  
USB 3.1 TYPE C Mid-Mount REC ASSY (T/H R/A)

製圖 (DR)  
17/11/28 CHANG CHUN WEI

審核 (CHKD)  
CHANG CHUN TE

核准 (APPD)  
JACK KUO

圖號 (DWG.NO)  
55999-024XX-XXX

比例 (SCALE) 單位 (UNITS)  
4:1 mm

張數 (SHEET) 1 OF 2  
SIZE A4  
REV 0

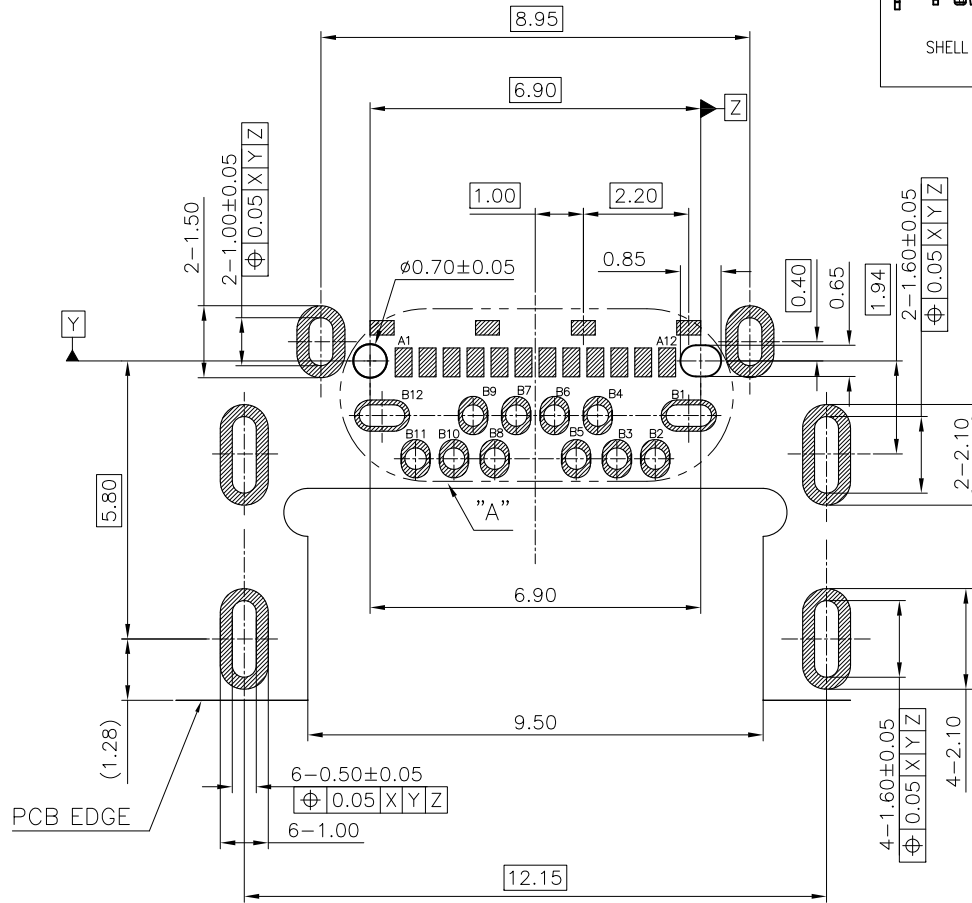

RECOMMENDED PCB LAYOUT

TOP VIEW  
SCALE 8:1

THICKNESS IS 1.0mm  
TOLERANCE ± 0.05

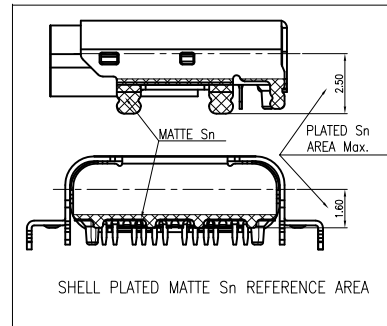

NOTES:

- 1.0 ELECTRICAL CHARACTERISTICS:
  - 1.1 LOW LEVEL CONTACT RESISTANCE:  
INITIAL : 40mΩ FOR ALL CONTACT MAX.  
AFTER : 10mΩ MAX. CHANGE.
  - 1.2 DIELECTRIC WITHSTANDING VOLTAGE :  
100 VAC FOR 1 MINUTE SEA LEVEL.
  - 1.3 INSULATION RESISTANCE :  
100MΩ MIN.
  - 1.4 CURRENT RATING :  
VBUS AND GND CONTACT RATED AT 1.25 A EA .  
PARALLELED FOR A TOTAL OF 5A .
- 2.0 MECHANICAL CHARACTERISTICS :
  - 2.1 INSERTION FORCE : 5N MIN. 20N MAX.
  - 2.2 EXTRACTION FORCE : 8N MIN. 20N MAX (INITIAL) .  
6N MIN. 20N MAX. (AFTER LIFE TEST)
  - 2.3 DURABILITY : 10,000 CYCLES
- 3.0 OPERATING TEMPERATURE : -40°C TO +85°

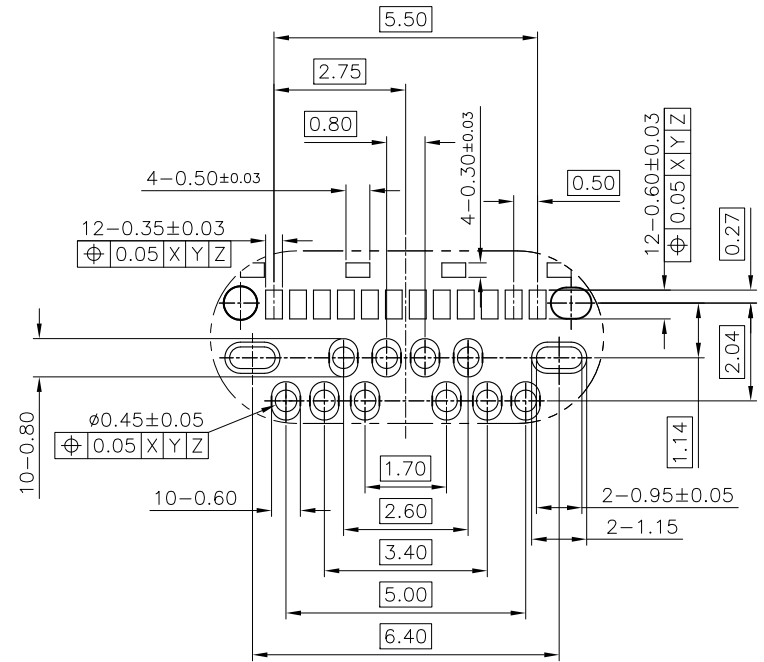

DETAIL A

一般公差 <b>TOLERANCES</b> X ±0.50 .XX ±0.15 X ±0.20 .XXX ±0.10 ANGLES X°±3° .X°±2° .XX°±1°		<b>宏致電子股份有限公司</b> <b>Aces Electronics Co.,Ltd.</b>	
檢驗尺寸標示 SYMBOLS   INDICATE CLASSIFICATION DIMENSION MARK IS CRITICAL DIM. MARK IS MAJOR DIM.		品名 (TITLE) USB 3.1 TYPE C Mid-Mount REC ASSY (T/H R/A)	
表面處理 (FINISH)		圖號 (DWG.NO) 55999-024XX-XXX	
比例 (SCALE) 4:1		單位 (UNITS) mm	
製圖 (DR) 17/11/28 CHANG CHUN WEI 審核 (CHKD) CHANG CHUN TE 核准 (APPD) JACK KUO		張數 (SHEET) 2 OF 2 尺寸 (SIZE) A4 版次 (REV) 0	